

# Sealing Sheet Pile

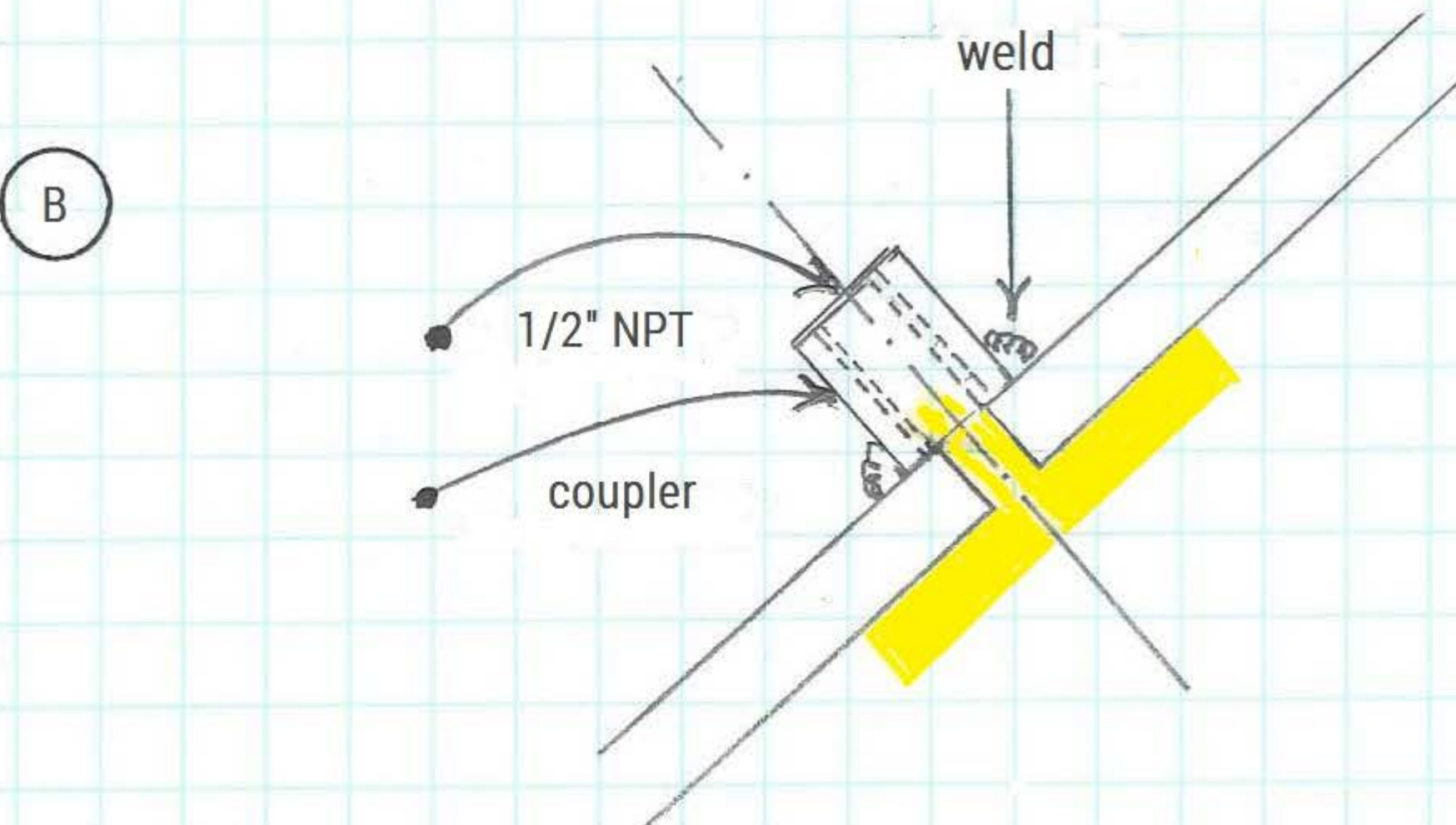

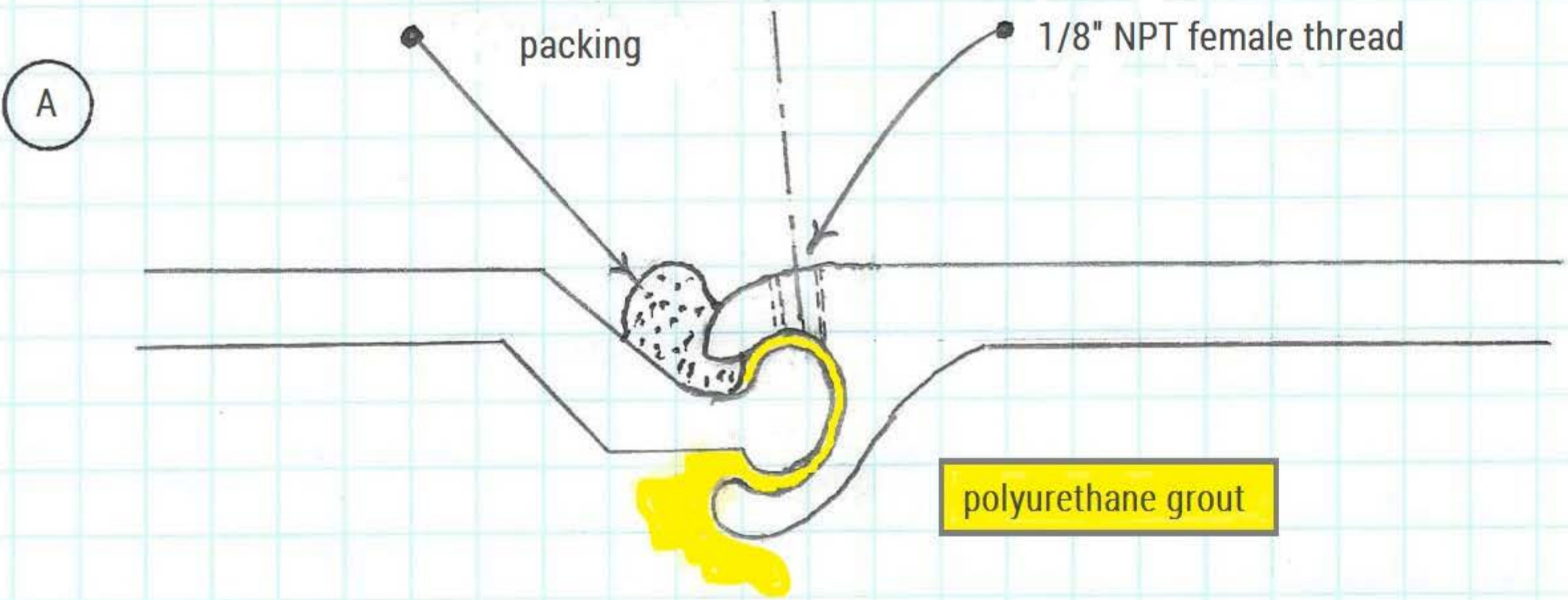
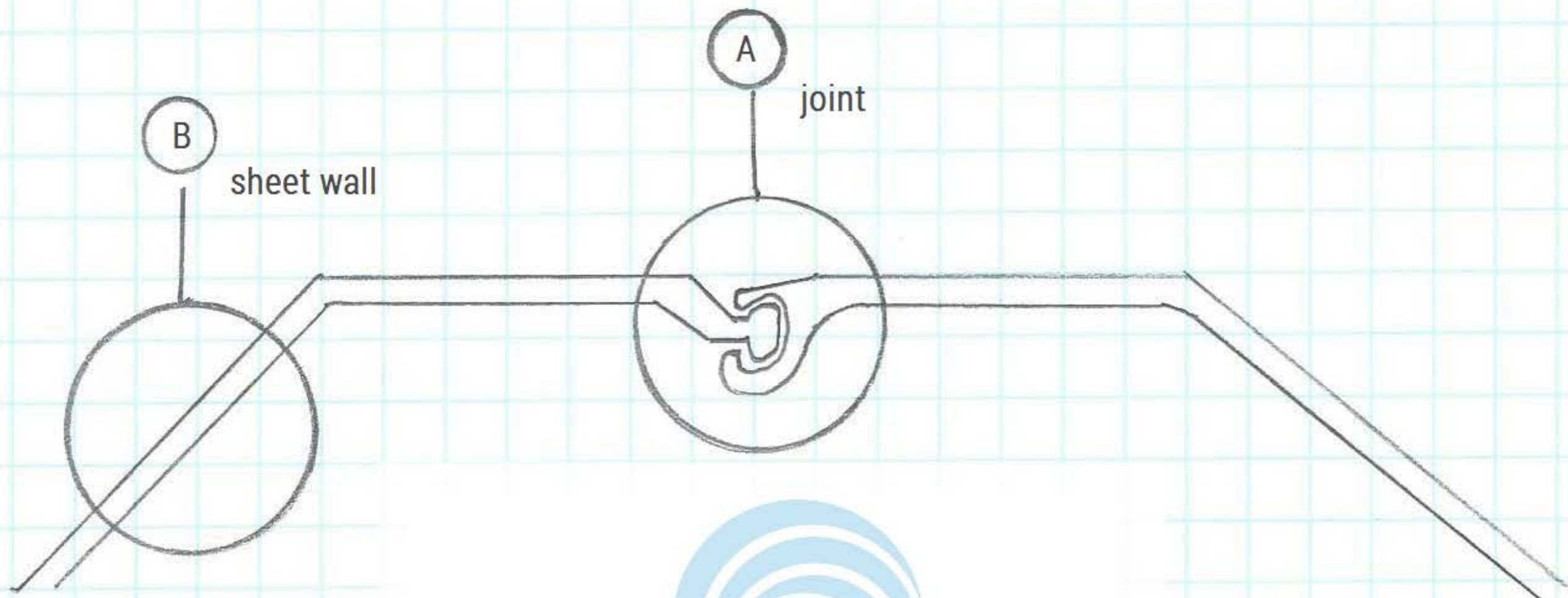

## Sealing Sheet Pile with Polyurethane Grout

### A) Injecting Grout into a Leaking Sheet Pile Joint

With an air powered drill, drill 1/8" hole to intersect the void that is leaking. Pack the joint with material (burlap or rags) to slow the infiltration. Use a flat screwdriver to wedge the material in further.

Tap & install a 1/8" zerk (grease) fitting or similar into the hole that was drilled.

Attach the female end of the zerk fitting that is hooked up to a grout pump (or grease gun) to the male end of the zerk that was attached to the sheet pile.

Inject the grout (SealGuard's Hyperflex) until refusal or the leak is sealed.

### B) Injecting Grout into Sheet Pile Wall

Solid weld 1/2" NPT coupler to sheet wall.

With an air powered drill, drill a 3/8" hole through the coupler (not touching the coupler) into the sheet pile.

Install a shut off valve onto the coupler.

Hook up injection pump and inject the grout (SealGuard's SealGuard II) to seal or fill the leakage or void.

